

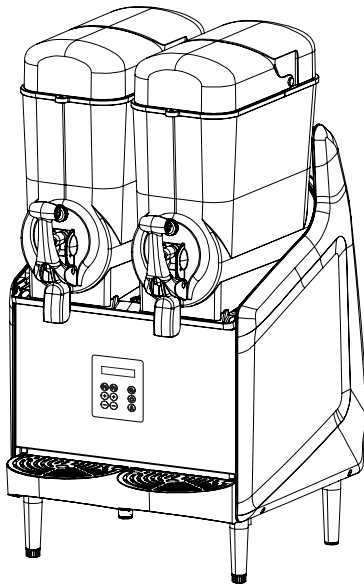

# Slush machine

## OPERATING INSTRUCTIONS

Read these operating instructions carefully before using the machine



09504004/ 09504005/ 09504006

# INDEX

<b>1. GENERAL INFORMATION .....</b>	<b>2</b>	6.2 Preparing the product .....	7
1.1. Manufacturer .....	2	6.3 Starting a Granitore .....	8
1.2. Authorized persons .....	2	6.4 To Serve with Granita .....	8
1.3. Layout of the manual .....	2	6.5 To Serve with Cold Liquid Drinks .....	8
1.3.1. Purpose and contents .....	2	6.6 Simple clean the corresponding bowl .....	9
1.3.2. Who must read the manual .....	2	6.7 To stop working.....	9
1.3.3. How to keep the manual .....	2	6.8 Regeneration mode .....	9
1.3.4. Symbols used .....	2	6.9 Light operation .....	9
<b>2. MACHINE DESCRIPTION .....</b>	<b>3</b>	6.10 Emergency Situation .....	9
2.1. Use of the machine .....	3	<b>7. CLEANING AND MAINTENANCE .....</b>	<b>9</b>
2.2. Main components .....	3	7.1. Emptying the bowls.....	10
2.3. Technical Data .....	3	7.2. Removing the lid .....	11
2.4. Control panel .....	4	7.3. Removing the handle .....	11
<b>3. SAFETY .....</b>	<b>4</b>	7.4. Removing the bowl and the lid.....	11
3.1. General safety rules .....	4	7.5. Washing and sanitizing the components .....	12
3.2. Stop functions .....	5	7.6. Reassembling the washed components.....	12
3.3. Plates .....	5	7.7. Cleaning the drip tray.....	13
<b>4. HANDLING AND STORAGE .....</b>	<b>5</b>	7.8. Cleaning the Filter .....	14
4.1. Packaging .....	5	7.9. Periodic maintenance .....	14
4.2. Conveyance and handling .....	5	<b>8. SCRAPPING .....</b>	<b>14</b>
4.3. Storage .....	5	<b>9. TROUBLESHOOTING .....</b>	<b>14</b>
<b>5. INSTALLATION .....</b>	<b>6</b>	<b>10. BASIC WIRING DIAGRAMS.....</b>	<b>15</b>
5.1. List of accessories provided .....	6	<b>11. PARTS DIAGRAMS .....</b>	<b>19</b>
5.2. Installation-Positioning .....	6		
5.3. Disposal of packing materials .....	6		
5.4. Electrical connection .....	6		
<b>6. OPERATION .....</b>	<b>7</b>		
6.1 Preparing the product .....	7		

# 1. GENERAL INFORMATION

## 1.1. Manufacturer

The manufacturer's details are shown on the identification plate, illustrated on first and/or last page of the manual.

## 1.2. Authorized persons

Two types of persons may access the machine for different purposes.

### User

A person who has adequate technical training to prepare the products the machine uses to dispense granita, in observance of current standards of hygiene. After reading this manual, he will be capable of:

- carrying out normal product loading and/or replacement operations;
- properly dispensing the product;
- cleaning and sanitizing the machine.

### Specialized technician

A person who has examined this manual and has specific training in the installation, use and servicing of the granita machine:

- he must be able to carry out repairs in the event of serious faults and be well acquainted with this manual and all the information regarding safety;
- he must be able to understand the contents of the manual and correctly interpret drawings and diagrams;
- he must be familiar with the most important sanitary accident prevention, technological and safety standards;
- he must have specific experience in servicing granita machines;
- he must know how to behave in case of emergency where to find individual safety equipment and how to use it properly.



Persons who do not meet the above requirements must not be allowed to use the machine.

## 1.3. Layout of the manual

The Purchaser must very carefully read the information contained in this manual.

### 1.3.1. Purpose and contents

The purpose of this manual is to provide the Purchaser with all the necessary information regarding the installation maintenance and use of the granita machine.



Before carrying out any operation on the machine, users and specialized technicians must carefully read the instructions Herein.

Should you have any doubts as to the correct interpretation of these instructions, contact the manufacturer to request the necessary explanations.



You should not carry out any type of operation until you have read and thoroughly understood the contents of this manual.

### 1.3.2. Who must read the manual

This manual is aimed at users and specialized technicians.

Users must not attempt to carry out any operations restricted to qualified technicians.

The manufacturer will not be liable for any damage or injury caused as a result of failure to comply with this rule.

The instruction manual is an integral part of the product purchased and must therefore be handed over to any subsequent owners.

### 1.3.3. How to keep the manual

This instruction manual must be kept in the immediate vicinity of the machine.

Due precautions should be taken to ensure that the manual is maintained intact and legible over time:

- Use the manual in such a way as to avoid damaging any of its contents.
- Do not for any reason remove, tear or rewrite parts of the manual.
- Keep the manual in a place that is protected against humidity and heat in order to preserve the quality of the print and the legibility of all its parts,



If the present instruction manual is damaged or lost, another copy should be immediately requested from the manufacturer or authorized distributor in the user's country.

### 1.3.4. Symbols used

#### GENERAL DANGER WARNING



It indicates a danger which may also place the User at mortal risk. In such cases utmost care is required and every precaution must be taken in order to operate safely.

#### DANGER OF ELECTROCUTION



It warns the personnel concerned that the operation described may result in an electric shock unless all the necessary safety precautions are taken

#### IMPORTANT



It indicates a cautionary note, a note about key functions or useful information. Very close attention should be paid to the portions of text marked with this symbol

#### PROHIBITED



This symbol is used to indicate operations that must absolutely be avoided since they create hazards for the User and any other individuals present in the vicinity.

#### DO NOT EXTINGUISH FIRES WITH WATER



The presence of this symbol warns against attempting to extinguish fires with water or any substance containing water.

#### PERSONAL PROTECTION



When this symbol appears alongside a description it means that personal safety equipment must be used, as there is an implicit risk of accidents.

#### SPECIALIZED TECHNICIAN



it identifies operations that may be performed only by qualified technical personnel.

safety devices have been changed;

#### MOVING MACHINE PARTS



It identifies the danger due to moving parts existing in the machine. Turn off the machine before carrying out any operation.

## 2. MACHINE DESCRIPTION

### 2.1. Use of the machine

The professional machine you are using is suitable for making slush drinks and cold beverages, if used with dairy-based products and/or when envisaged by law in according to the type of product used, it must be equipped with the optional extra of a temperature gauge for the product in the bowl. It is also obligatory to comply with the current regulations and standards concerning the products used.

The appliance is not intended for use by persons (including children) with reduced physical, sensory or mental capabilities, or lack of experience and knowledge, unless they have been given supervision or instruction concerning use of the appliance by a person responsible for their safety.

### 2.2. Main components

The main components making up the machine are:

- 1 Bowl lid
- 2 Bowl
- 3 Control panel
- 4 Drip tray
- 5 Lid of drip tray
- 6 Float (overflow indicator)
- 7 Tap
- 8 Handle
- 9 Feet
- 10 Adjustable feet
- 11 Bottom power switch( Only 110V machine has this switch)

Fig. 1

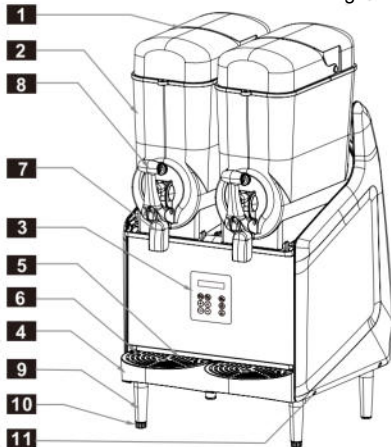

To make the instructions easier to read, the following abbreviations are used herein:

- 09504004 , identifies a slush machine with one (1) bowl for outdoor use;
- 09504005 , identifies a slush machine with two (2) bowls for outdoor use;
- 09504006 , identifies a slush machine with three (3) bowls for outdoor use.

### 2.3. Technical Data

The technical data and features are listed below

For indoor use :

Model	09504004	09504005	09504006
Dimensions L*D*H (cm)	28x61x94	49.6x61x94	71.4x61x94
Net Weight (kg)	35	57	78
Maximum Electrical Input (W)	See rating plate on side of machine		
Operating voltage (V).			
Operating temperature	Min. 5°C/41°F Max. 32°C/89.6°F		
Number of bowls.	1	2	3
Capacity of each bowl (L)	12		
Noise level	<60dB		

For outdoor use:

Model	09504004	09504005	09504006
Dimensions L*D*H (cm)	28x61x94	49.6x61x94	71.4x61x94
Net Weight (kg)	35	57	78
Maximum Electrical Input (W)	See rating plate on side of machine		
Operating voltage (V).			
Operating temperature	Min. 5°C/41°F Max.43°C/ 109°F		
Number of bowls.	1	2	3
Capacity of each bowl (L)	12		
Noise level	<60dB		



The manufacturer reserves the right to make changes to the machine without notice.



Important! Any changes and/or additions of accessories must be explicitly approved and implemented by the Manufacturer.

Fig. 2

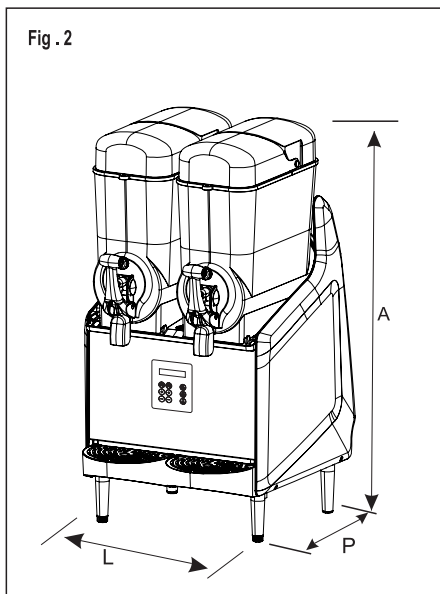

### 3. SAFETY



#### 3.1. General safety rules

- Carefully read the whole instruction manual.
- The connection to the electricity mains must comply with the current safety standards in the user's country;
- The machine must be connected to an electricity outlet that is:
  - compatible with the provided with the machine;
  - of dimensions conforming to the data shown on the rating plate on the side of the machine;
  - properly grounded;
  - connected to a system provided with a differential switch and circuit breaker.
- The power cord must not be:
  - allowed to come into contact with any kind of liquid: danger of electric shocks and/or fire;
  - crushed and/or brought into contact with sharp surfaces;
  - used to move the machine;
  - used if it shows any damage;
  - handled with damp or wet hands;
  - wound into a coil when the machine is on.
  - tampered with.
- The installation of the appliance and the refrigerant condensing unit must only be made by the manufacturer's service personnel or similarly skilled person.

#### DO NOT:

- Install the machine in a manner other than that described in Chap. 5.
- Install the machine in a place where it may be exposed to sprays of water,
- use the machine near inflammable and/or explosive substances.
- leave plastic bags, polystyrene, nails etc. within children's reach, since they are potential sources of danger,
- allow children to play or stay near the machine,
- use spare parts other than those recommended by the manufacturer,
- make any technical changes to the machine,
- immerse the machine in any kind of liquid.
- spray water on the machine to wash it.
- use the machine other than as directed in this manual.
- use the machine when not in full possession of your mental and physical faculties: under the influence of drugs, alcohol, etc.
- install the machine on top of other equipment,
- use the machine in an explosive or aggressive atmosphere or in the presence of a high concentration of dust or only substances suspended in the air;
- use the machine in a place where there is a risk of fire;
- use the machine to dispense substances that are not compatible with the machine's specifications;
- Before cleaning the machine, make sure that it is unplugged; do not clean the machine with gasoline and/or solvents of any kind.
- Repair work may be performed only by a Service Center authorized by the Manufacturer and/or specialized, trained personnel,
- Do not obstruct the grill vents on the side of the machine.
- Do not site the machine near heating equipment (stoves or radiators).
- In case of fire, use carbon dioxide(CO2) extinguishers. Do not use water or powder extinguishers.

#### 2.4. Control panel (09504006 as the sample)

Fig.3

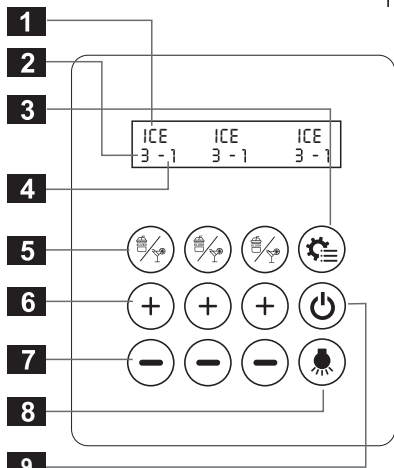

- |                       |                 |
|-----------------------|-----------------|
| 1 Mode Display        | 6 Gear Increase |
| 2 Gear Display        | 7 Gear Decrease |
| 3 Setting             | 8 Light Switch  |
| 4 Temperature Display | 9 Power Switch  |
| 5 Model Switch Button |                 |



**In the event of improper use, all warranty rights will be forfeited and the manufacturer will accept no liability for injury or damage to persons and/or property.**

The following are to be considered improper use:

- any use other than the intended use and/or with methods other than those described herein;
- any operation on the machine that is in contrast with the directions provided herein;
- use of the machine after any components have been tampered with and/or

- safety devices have been changed;
- use of the machine after it has undergone repair with components not authorized by the manufacturer;
- outdoor installation of the machine.

### 3.2. Stop functions

The machine is shut down by turning off the main switch.

### 3.3. Plates

**NONE OF THE PLATES OR LABELS APPLIED ON THE MACHINE MUST BE REMOVED, COVERED OR DAMAGED, ESPECIALLY THOSE RELATING TO SAFETY.**

## 4. HANDLING AND STORAGE



All the operations described in chapter 4 may be carried out exclusively by technicians who are also specialized in the lifting and handling of packed or unpacked machines. They must organize all the operational sequences and use suitable equipment, according to the characteristics and weight of the object to be handled and in strict compliance with the applicable regulations currently in force.



### 4.1. Packaging

This machine is shipped ready for use in a polywood case. The polywood case comprises a pallet base and a cover, which are secured together with screws.

#### DIMENSIONS AND WEIGHT OF PACKING CONTAINER

	Width(L)	Depth(P)	Height(H)	Weight
09504004	345 mm	610 mm	1090 mm	50 kg
09504005	560 mm	610 mm	1090 mm	76 kg
09504006	780 mm	610 mm	1090 mm	101 kg

Fig . 4

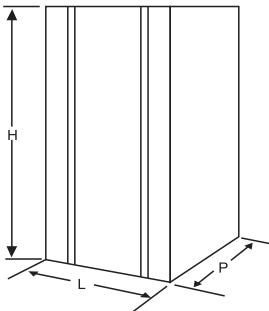

Note: the dimensions and weight of the packing container are approximate.

### 4.2. Conveyance and handling



**Make sure that no one is stationed within range of lifting and handling operations. In difficult conditions, specialized personnel should be appointed to oversee the movements of the machine.**

Manual handling of the machine requires at least two people.

**The machine must be moved into an upright position, only after every bowl has been emptied of product.**

Lift the box and carefully convey it, avoiding mutes with obstacles. Pay attention to the overall dimensions and any parts sticking out.



**Warning: do not make any additional cuts on the packing container.**

The WARRANTY does not cover damage caused to the machine during its conveyance and handling.

The Purchaser will bear the cost of repairing or replacing damaged parts

### 4.3. Storage



**Before the machine is placed in storage and whenever the machine is started up again after a period of storage, it must be thoroughly cleaned and sanitized.**

**Warning: do not store more than three machines stacked on top of one another.**

If the machine is to remain unused for a long period of time due precautions must be taken with respect to the place and duration of storage:

- store the machine in a closed place;
- protect the machine from shocks and stresses;
- protect the machine from humidity and large temperature fluctuations;
- prevent the machine from coming into contact with corrosive substances.

Fig . 5



## 5. INSTALLATION



All of the operations described in chapter 5 may be carried out exclusively by specialized technicians, who must organize all the operational sequences and use suitable equipment, in strict compliance with the applicable regulations currently in force.



The machine is of the attended type, and must be installed in places where it can be monitored by trained personnel.



**Warning:** it is forbidden to install the machine in a place where it may be reached, touched and/or operated by persons other than those specified in section 1.2.

The machine must be installed in a well-lit and well-ventilated place with a firm, solid, level floor (slope less than 2°)

The indoor model Model X I/II/III must only operated in place with an ambient temperature ranging between 5°C-32°C.

The outdoor model Model X I/II/III Turbo may only operated in place with an ambient temperature ranging between 5°C-43°C.

### 5.1. List of accessories provided

**Vaseline:** to lubricate all of the parts indicated in this manual after washing and sanitization operations

### 5.2. Installation-Positioning

The installer must check that:

- the site has been duly prepared for machine installation;
- the surface the machine will be installed on is firm, flat and solid; if the surface is not even, you can adjust the adjustable feet of the machine to install the machine.
- the room is adequately lit, ventilated and hygienic and an electric outlet is within easy reach.



Adequate clearance must be left at the back side of the machine to enable personnel to work without any constraints and also leave the work area immediately in case of need.

Fig.6 shows the minimum clearances for installation

Fig. 6

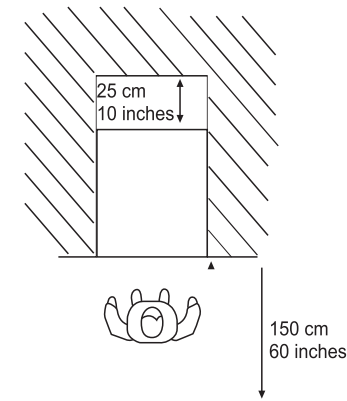

### 5.3. Install the handle

- Fix the "A" position of the handle to the "B" position of the bowl.
- Press the handle and lift it up, then pull it down, ensure the the click "C" position will be fix the handle and the bowl together.
- Tighten the screw of the "E" position.

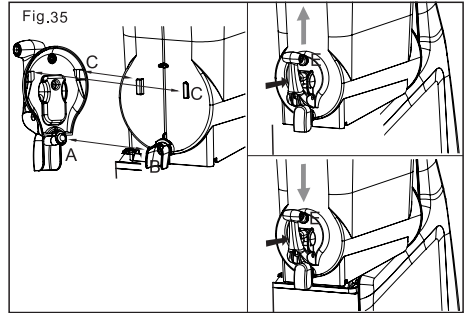

**WARNING:** Correctly install the components as shown in the figure.

The non-lubrication of the cap may cause product leakage from the tap.

### 5.4. Disposal of packing materials

After opening the box, make sure to separate the packing materials according to type and dispose of them in accordance with the current regulations in the user's country.

We recommend keeping the box for future conveyance or transport

### 5.5. Electrical connection



This job may be performed only by specialized technical personnel.

Before plugging in the machine, make sure that the main switch is on "OFF".

The Purchaser is responsible for making the electrical connection.

The machine must be connected to the electricity mains by means of the plug fitted on the power cord. Be sure to comply with: the technical regulations and standards in force at the time of installation; the data shown on the rating plate on the side of the machine.



**Warning:** the electric outlet must be situated in a place easily within reach of the user, so that no effort is required in order to disconnect the machine from the power supply when necessary.

If the power cord is damaged, you must have it replaced either by the manufacturer or a specialized technician



It is forbidden:  
to use extension cords of any type;  
to replace the original plug;  
to use adaptors.

## 6. OPERATION

Before the machine may be started up for the first time, specialized technical personnel must check that it functions properly.

### 6.1. Clean the machine

- 1.Fill the tank with clean water
- 2.choose the "CLN" simple clean mold to clean the machine for 1 min, please refer the operating to part 6.5
- 3.Turn off the machine and empty the tank by opening the tap.

### 6.2. Preparing the product



**Warning:** Product may be poured into the bowl only when the machine is off and unplugged.

NEVER USE ONLY WATER

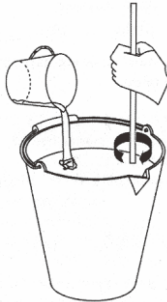

Fig . 7



**Warning:** The sugar content of the material should be within 5% - 18%, the alcohol content of alcoholic beverage material should be less than 20%.

Take out the lock and open the lid

Fig . 8

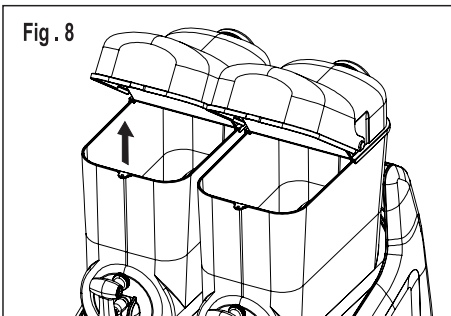

**Warning:** do not force the lid opening in case of difficulty.

NEVER INTRODUCE HOT LIQUIDS  
(with temperatures exceeding 25°C)

Fig . 9

MAXIMUM LEVEL

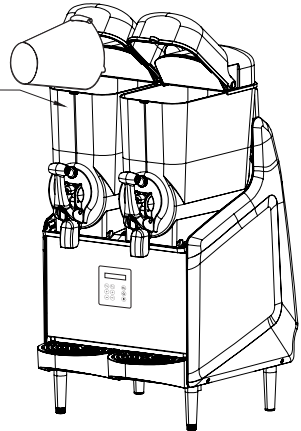

**Warning:** Pour the product into the bowl taking care that it never goes above the max level.

Fig . 10

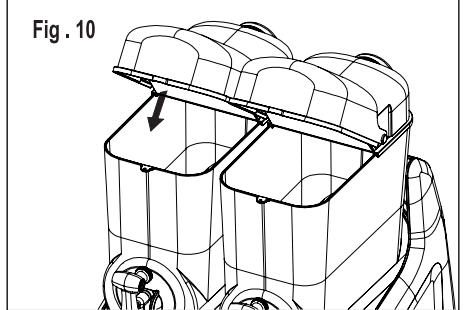

After pouring the product into the bowl, close the lid



**Warning:** never switch on the machine if the lid is missing. Before removing the lid, switch off the machine and unplug it. The pad-lock keys must be kept safely by the user.



**Warning:** There are some moving parts inside the bowl, which may cause injuries; turn off and unplug the machine before carrying out any operation inside the bowl.

### 6.3. Starting a Granitore

For the sake of simplicity only the operation of the right bowl will be illustrated to operate the other bowls simply carry out the same sequence of the steps on the buttons of the bowl in question.

Press the power switch  on the control panel to turn on the machine.

Please note that for the 110V machine, you need to press the bottom switch first, and then press the power switch  on the panel to start the machine.

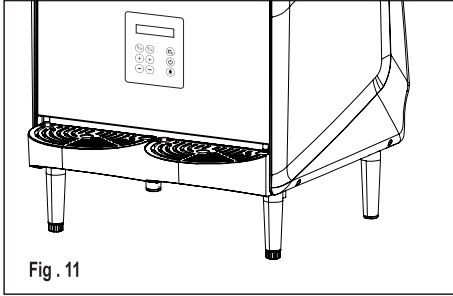



Fig. 11



**NOTE:** If not touched for more than 1 minute, the control panel will be automatically locked. The control panel cannot be operated under the lock screen. Press and hold the light button for 3 seconds to unlock the control panel.

- **Change the working status of the corresponding bowl**

Press the button  for a second to select the working mode. There are four working modes, granita, juice, wash and stop. When the temperature of the machine is less than 0°C, there will be extra "Regeneration" mode.

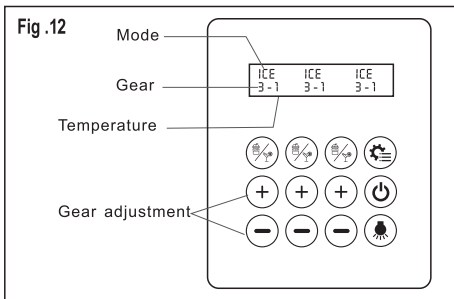

### 6.4. To Serve with Granita



Press the corresponding bowl button . the screen display granita mode ICE, then press   to adjust from 1st gear to 7th gear. The higher gear you adjust, the slush will be thicker and with less water content

Fig. 13



The temperature range of slush mode is -12°C~-2 °C. When the ice is too hard, may cause the slush stuck at the outlet can't be out or go out slowly.

### 6.5. To Serve with Cold Liquid Drinks

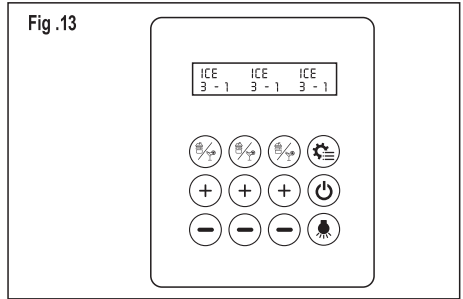

Press the corresponding bowl button  the screen display juice mode COOL, then press   to regulate temperature.

Fig. 14



The gears under juice mode correspond to the following:

Gear	Temperature
1	1~4°C
2	2~5°C
3	3~6°C
4	4~7°C
5	5~8°C
6	6~9°C
7	7~10°C

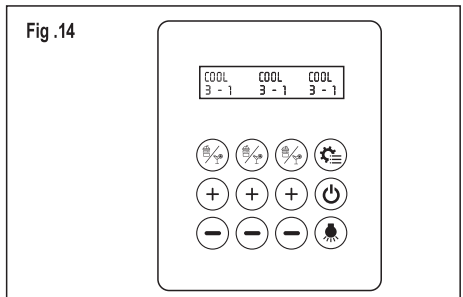
## 6.6. Simple cleaning mold



Press the corresponding bowl button  the screen display wash mode CLN, then it would keep stirring and the bowl would stop refrigerating.

Fig.15



CLN	CLN	CLN
- 1	- 1	- 1



When the simple cleaning mold has been turn on, the machine will stop refrigerating, the paddle will keep stirring, please fill the warm and clean water into the corresponding bowl not exceeding the maximum level line which is marked on the bowls.

## 6.7. To stop working

Press the corresponding bowl button  the screen display stop mode STOP, then it would stop stirring and the bowl would stop refrigerating.

Fig.16



STOP	STOP	STOP
- 1	- 1	- 1

## 6.8. Regeneration mode

Fig.17

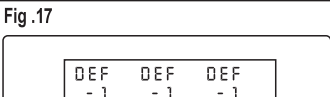

DEF	DEF	DEF
- 1	- 1	- 1





Press the corresponding bowl button  the screen will display regeneration mode DEF, then it would enter regeneration mode.

When the regeneration mold has been turn on, the machine will be start heating.

**WARNING:** Only when the temperature of machine is less or equal to 0°C , the Regeneration will be appear. When the temperature of the machine up to 4 °C, the regeneration mold will be finish, then the machine will turn to Juice mode.



## 6.9. Light operation

1. Press the button  and the lights on.
2. Press the button  for 3 second, the light start to be flashed.
3. Press the  or  of corresponding bowl to choose the light color you want, there are 0-63 color options, "0" means light off.

## 6.10. Emergency situations



**WARNING:** in every emergency situation, to shut down the machine, firmly press the main switch into position "OFF".

In case of freezing, switch off the machine and contact a service center or specialized technician.



If a fire breaks out, the area must be immediately cleared to make way for trained personnel provided with suitable safety equipment. Always use approved extinguishers, never use water or substances of dubious nature.

## 7. CLEANING AND MAINTENANCE



Before undertaking any cleaning and maintenance of external machine components, make sure that the main switch is positioned on "OFF" and that the machine is unplugged.



Before performing any cleaning and maintenance operation on the machine, wear the personal protections (gloves, glasses, etc.), which are recommended by the safety standards in force in the country where the machine is used

Cleaning preparation:

- cleaning tools (bucket, hairbrush, rag)
- clean water and hot water below 50 Celsius degree
- neutral detergent used in food utensils
- disinfectant (2% sodium hypochlorite saline solution) used in food utensils
- lubricant (or Vaseline) used in food utensils

When performing the Cleaning and Maintenance operations, follow these instructions:

- wear protection accident-proof gloves;
- do not use solvents or inflammable materials;
- do not use abrasive and/or metal sponges to clean the machine and it's components;
- take care to avoid dispersing liquids in the surrounding area;
- do not wash machine components in a dishwasher;
- do not dry parts of the machine in a conventional and/or microwave oven;
- do not immerse the machine in water;
- do not expose the machine to direct sprays of water;
- for cleaning use only lukewarm water and a suitable sanitizing agent (conforming to current regulations in the user's country) that will not risk damaging machine components;
- on completing work, make sure that all protective covers and guards that have been removed or opened are set back in place and properly secured.

Cleaning and sanitization are operations that must be performed with utmost care and on a regular basis to guarantee the quality of the beverages dispensed and compliance with mandatory hygiene standards.



The bowl must be cleaned and sanitized at least once a day and in any case, in compliance with the current hygiene regulations in the country of use. These operations need to be performed more frequently if demanded by the characteristics of the product used; for more details, contact the product supplier. If the machine is not used continuously throughout the day, wipe the dispensing tap area and the product outlet pipe with a clean cloth and sanitizing fluid, as illustrated in the figure below.

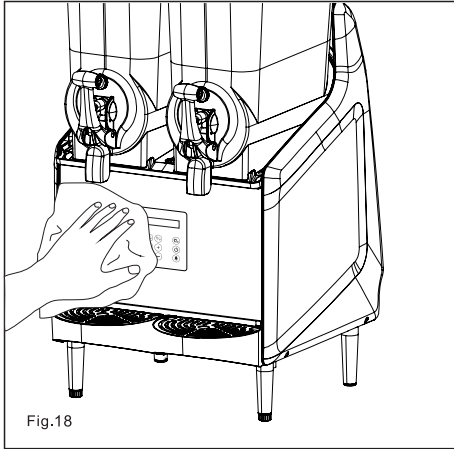

Fig.18



The stainless materials, plastic and rubber used to manufacture said parts, as well as their particular shape, make them easy to clean but do not prevent the build-up of germs and mold in the event of inadequate cleaning.



It is forbidden to clean or service the machine when it is plugged in and the main switch is positioned "ON".

To carry out maintenance and cleaning of the machine, it is possible to remove the upper parts of the side protections, if necessary Lift the upper part with no hesitation to remove them, Once finished, fit the part in the side protection again.

### 7.1. Emptying the bowls

Before a bowl may be cleaned, it must be emptied of the previously prepared product.

If the bowl is to be cleaned prior to the first use of the machine, it need not be emptied, In such a case refer directly to section 6.1.

For the sake of simplicity only the operation of the right bowl will be illustrated; to operate the other bowl simply carry out the same sequence of steps on the switches of the bowl in question,

Set the bowl to simple cleaning mode if it need to be cleaned, and then release all the material inside the bowl, as fig. 19

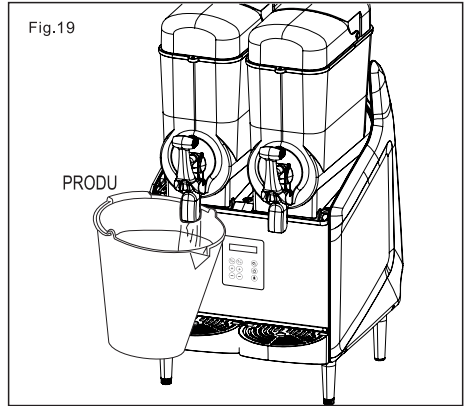
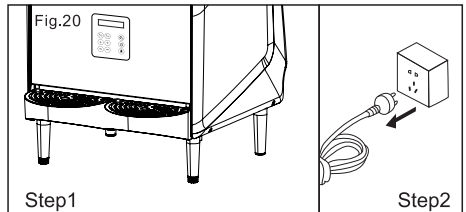

Fig.19

Turn off the power switch and unplug the machine

Fig.20



Step1

Step2

### 7.2. Removing the lid

To remove the lid correctly proceed as follows:

- 1、 Remove the Lock and raise the front lid;
- 2、 Push forward a little to get the whole lid out;

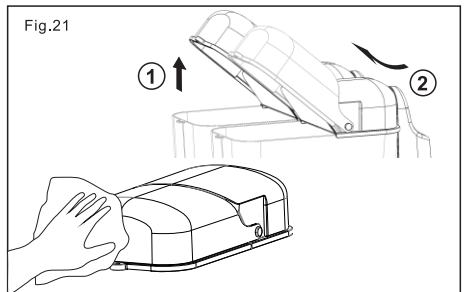

Fig.21



Warning: do not submerge lids equipped with lighting in any type of liquid. Before starting the cleaning and sanitising operations of the lid, remove it from the machine as described in the previous chapter.



It is forbidden to wash and/or sanitise the lid while it is installed in the machine.

### 7.3. Removing the handle seat

Remove the screw on the top.

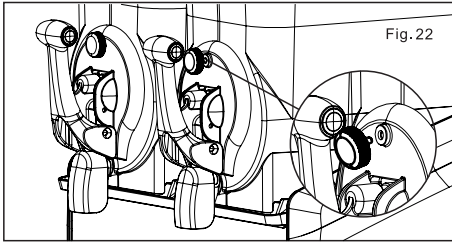

Hold the handle and outlet and lift it upward.

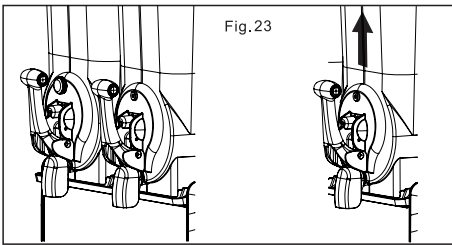

Remove the stopper and clean it with warm water.

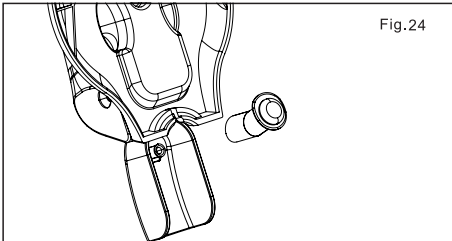

Clean the handle seat and other spare parts with warm water.

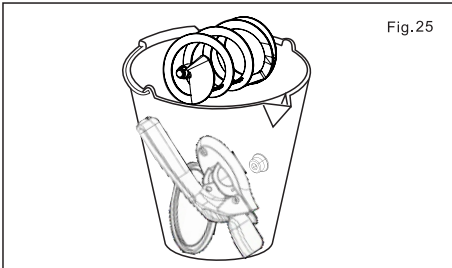

### 7.4. Removing the bowl and the lid

Removal of every machine bowl is fundamental to ensure correct machine cleaning and sanitization

To remove a bowl correctly proceed as follows

1. remove the lid as shown at paragraph 7.2
2. Remove the handle seat as paragraph 7.3
3. Raise the front part of the bowl to release it, remove the bowl from it's seat by pushing and tapping lightly on the rear.

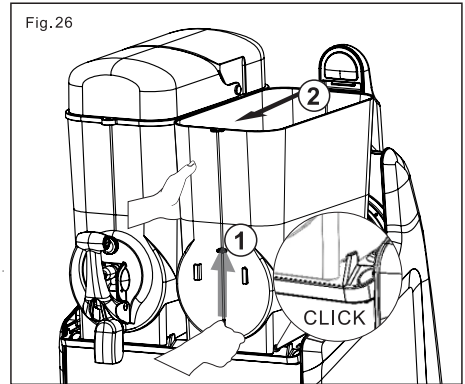

3. take out the bowl seal on the back

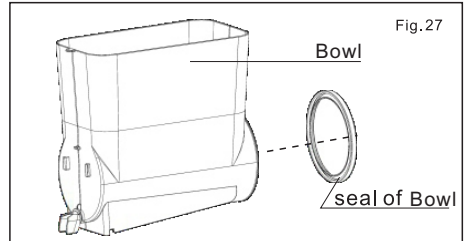

4. take out the auger and remove the seal of auger

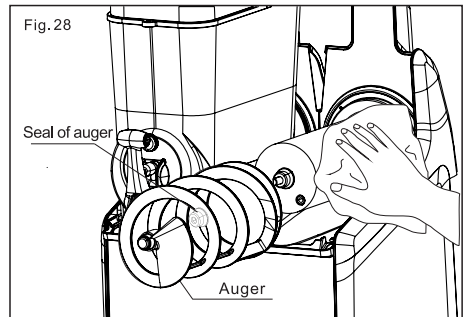

Wipe the cooler with a clean towel and remove any water stains.

Clean the bowl, seal of the bowl, auger and seal of the auger with warm water.

## 7.5. Washing and sanitizing the components

All of the previously disassembled and removed components must be thoroughly washed and sanitized.



**Important: the sanitizing solution must comply with the regulations in force at the time the machine is used.**

To carry out the procedure correctly, please use the following instructions:

1. Fill a container with a sanitizer solution mixed in water (2% of sodium hypochlorite mixed in water)
2. Thoroughly wash the tank, lid and evaporator with a sponge soaked in the sanitizer solution
3. Thoroughly wash again with clean water
4. Fill another container with a sanitizer solution
5. Dip the dismantled components into the sanitizer solution
6. Leave the dismantled components to soak in the solution for 30 minutes
7. Thoroughly wash again with clean water
8. Place the components on a clean surface and dry them
9. Assemble the machine as described in part 7.6
10. Before using the machine again carry out the rinsing cycle with clean water (part 6.1).

## 7.6. Reassembling the washed components.

All of the washed and sanitized components must be carefully reassembled. Some components must be adequately lubricated in order to ensure that they work efficiently.

Apply the seal (A) on the auger as shown in the fig. 29

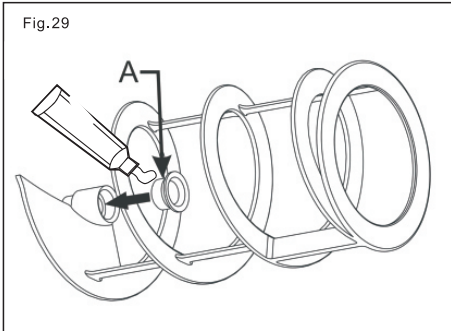

always check the seal integrity; should it be worn, replace it with a new one.  
Replace the seal (A) once a year at least.

Using the Vaseline provided, lubricate the seal (A) in the areas shown in the fig. 30

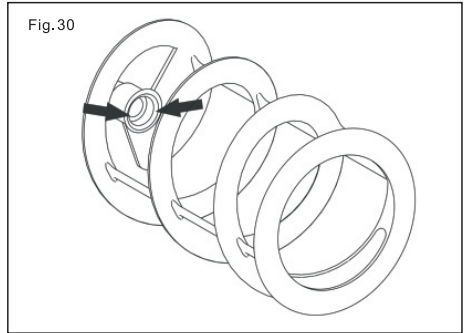

Apply seal (B), lubricating the entire surface indicated by the arrows with Vase-line

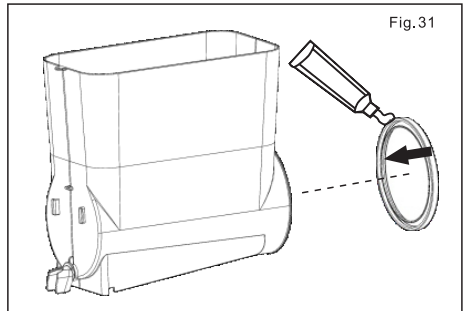
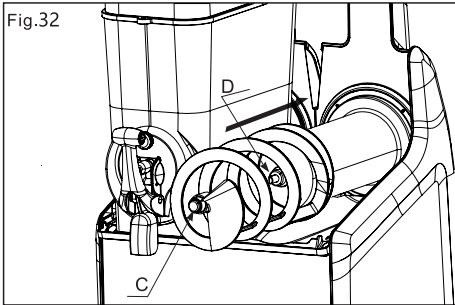

Fig. 29

Fig. 31

Introduce the auger, engaging head (C) with shaft (D).



rotate the auger to engage it.

Place the bowl on the seat, the bowls should be fit the click position, as the Fig.33 ①, then push the bowl to back side, ensure the bowls are fixed into the bottom seat.

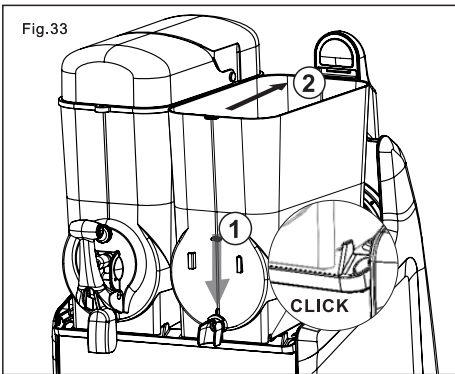

#### Install the handle

Please refer the operating of installing the handle to part. 5.3.

#### Install the lid :

Align the notch at the bottom of the top cover as shown in Figure 34-1 with the edge of the bowl as shown in Figure Then put it down and press it backward.

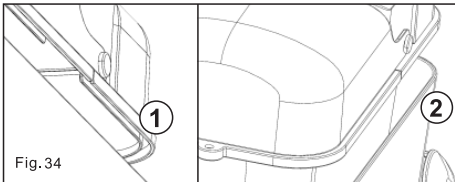

WARNING:Ensure that the lid is installed well.

#### 7.7. Cleaning the drip tray

The drip tray should be emptied and cleaned daily.

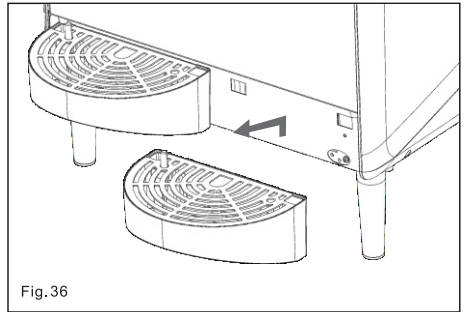

**all of the drip trays present in the machine should be cleaned.**  
The drip tray should be emptied and cleaned every time the red float installed in the grid rises into view.

Holding the drainage hose firmly, lift the tray with the grid on top of it and pull it out.

Wash the tray and grid separately with lukewarm water.

Dry all of the components.

Reposition the grid on top of the tray.

Position the drainage hose in the opening provided.

Fit the tray back in place and press down to secure it to the machine.

#### 7.8. Cleaning the filter



**A dirty filter or condenser will impair machine performance.**

Take out the filter on the bottom of the machine, clean the filter by clean water.

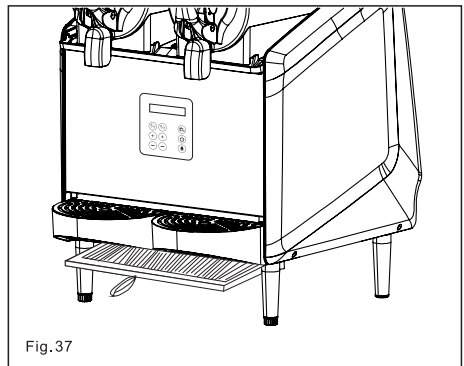

## 7.9. Periodic maintenance



The machine must be periodically checked (at least once a year) by a specialised technician. This periodic check serves to ensure that all the components installed and the machine itself are maintained at a high level of safety.



Any worn components must be replaced by an original spare part.



**It is forbidden to use the machine when even only one of its components is faulty or worn. Users are forbidden to perform periodic maintenance.**

## 8. SCRAPPING



**Electric and electronic equipment must be disposed of in accordance with the local law and regulations.**

Such equipment may not be disposed of as normal municipal solid waste but must rather be separately collected to optimise recovery and recycling of the materials used to manufacture them.



All products are marked with the crossed out wheeled bin symbol as a reminder of separate collection obligations. Correct observance of all of the provisions for the disposal of end-of-life products will contribute to safeguarding the environment.

## 9. Trouble Shooting

Problem	Cause	Remedy
Machine can't start.	No power supply	Insert the plug into a suitable outlet.
	The Main switch not at position "ON"	Press the Switch to position "ON".
The Tap leaks	The tap piston is not lubricated	Lubricated the tap piston
	The tap piston is defective	Replace the tap piston
Product leaks from the back of the bowl.	The bowl is not fitted correctly.	Check the positioning of the bowl.
	The bowl seal is not lubricated	Lubricated the bowl seal.
	The seal is defective	Replace bowl seal.
The Auger does not turn	The switch is positioned on "OFF"	Press the switch to position "ON".
	Blocked ice in the bowl	Switch off the machine and allow the ice to be melted.
The machine does not make granita	The Main switch not at position "ON"	Press the Switch to position "ON".
	The Working Status is not on slush mode	Change the working Status to slush mode
	The consistency has not been adjusted correctly	Adjust the consistency correctly
	There is insufficient ventilation .The condenser is dirty	Call a specialized person to clean the condenser
	The machine s near source of heat	Install the machine at suitable place
The Auger is noisy	The front seal has been applied incorrectly	Put the seal correctly
	The consistency is adjusted too thick	The consistency is adjusted too thick
	The seal is not lubricated	Lubricate the seal
	The product is with less sugar	Adjust the materials of product proportion and do not use mellitum instead
Granita has black stains	The bowl is dirty	Turn off the machine to let the ice be melted
	Auger seal is dirty	Clean again
	Auger seal is defective	Clean again
The tap doesn't distribute.	Ice blocked inside the bowl.	Turn off the machine to let the ice be melted.
If the machine malfunctions due to causes other than those listed in this table or proposed remedies do not solve the problem, please call a specialized technician.		

## 10. BASIC WIRING DIAGRAMS

220V MODELS:

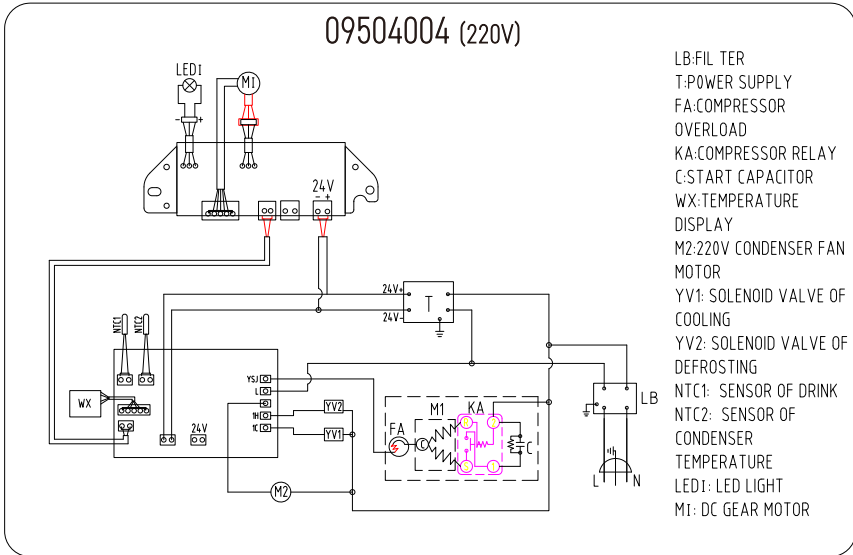

# 10. BASIC WIRING DIAGRAMS

## 220V MODELS:

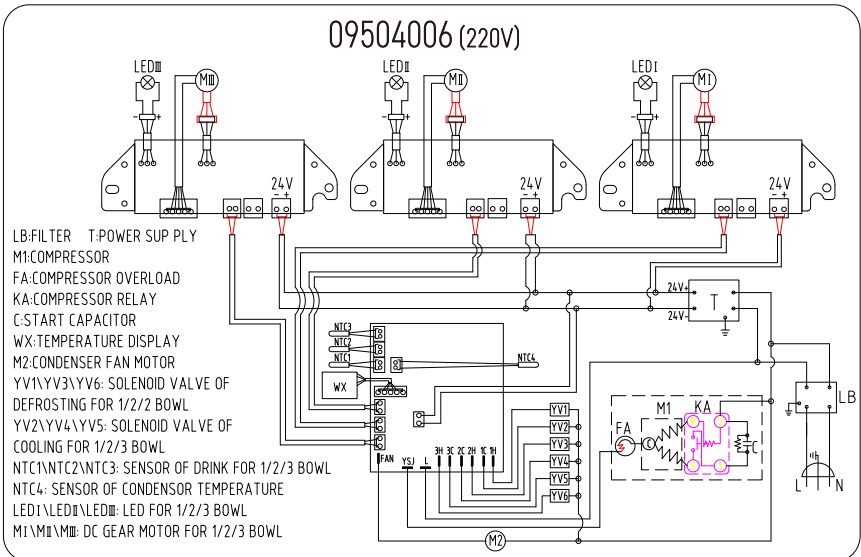
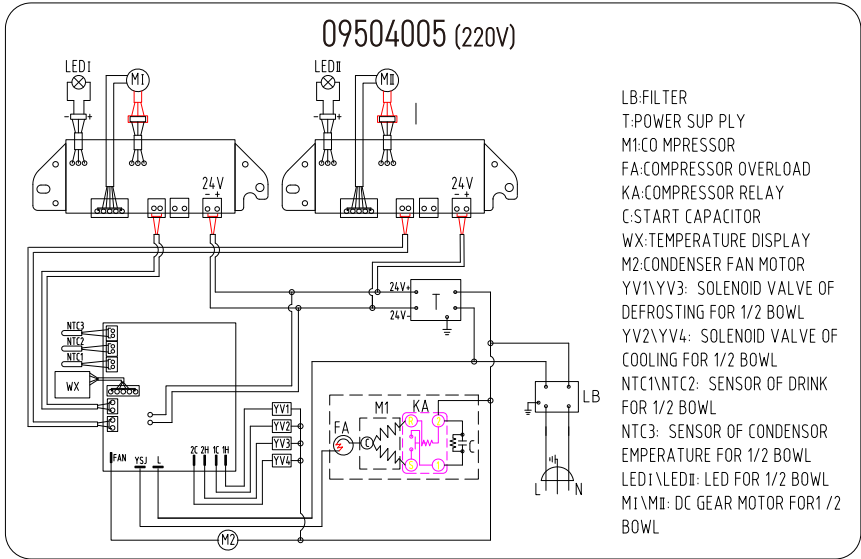

## 10. BASIC WIRING DIAGRAMS

110V MODELS:

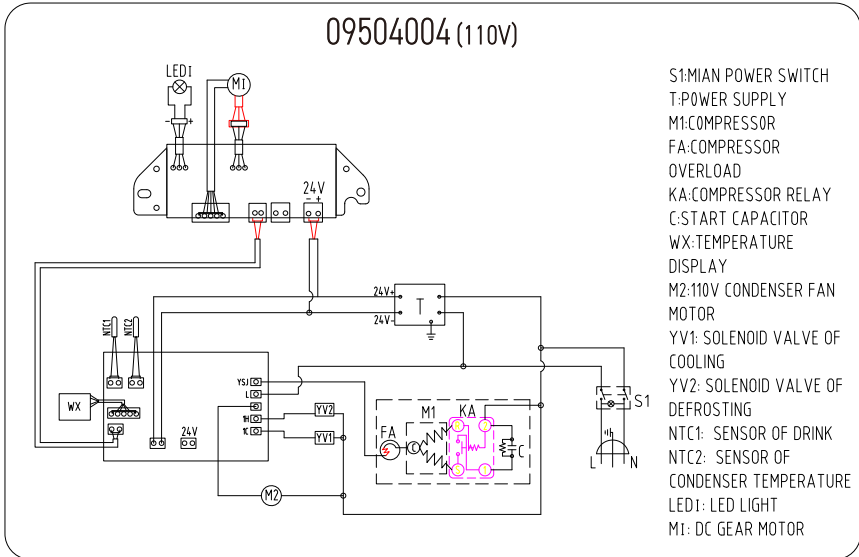

# 10. BASIC WIRING DIAGRAMS

110V MODELS:

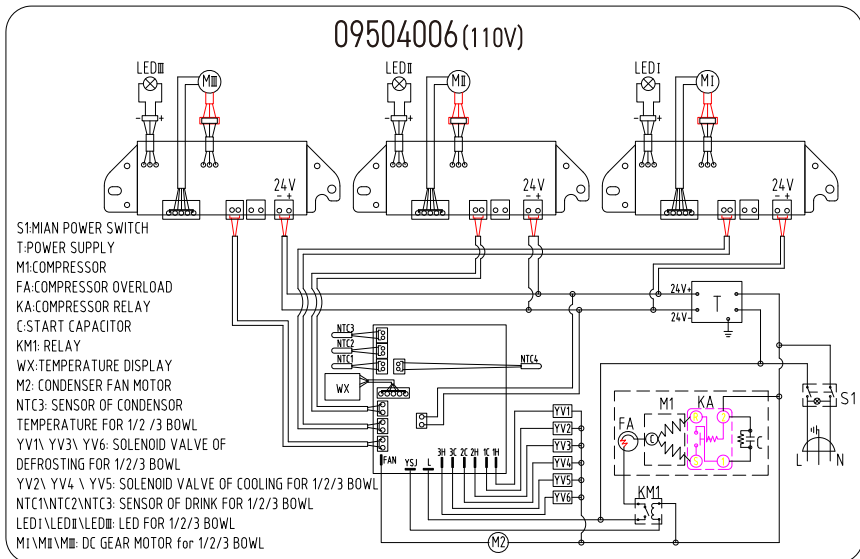
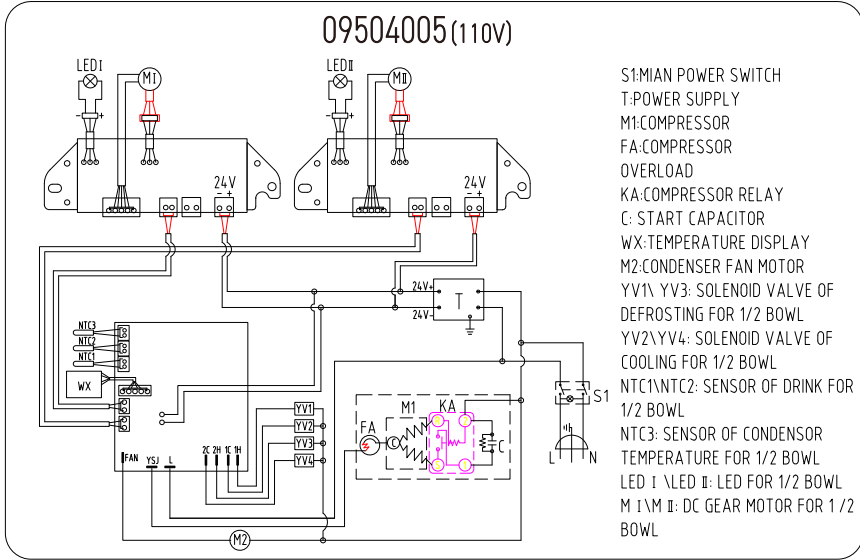

# 11. PARTS DIAGRAMS

220V MODELS:

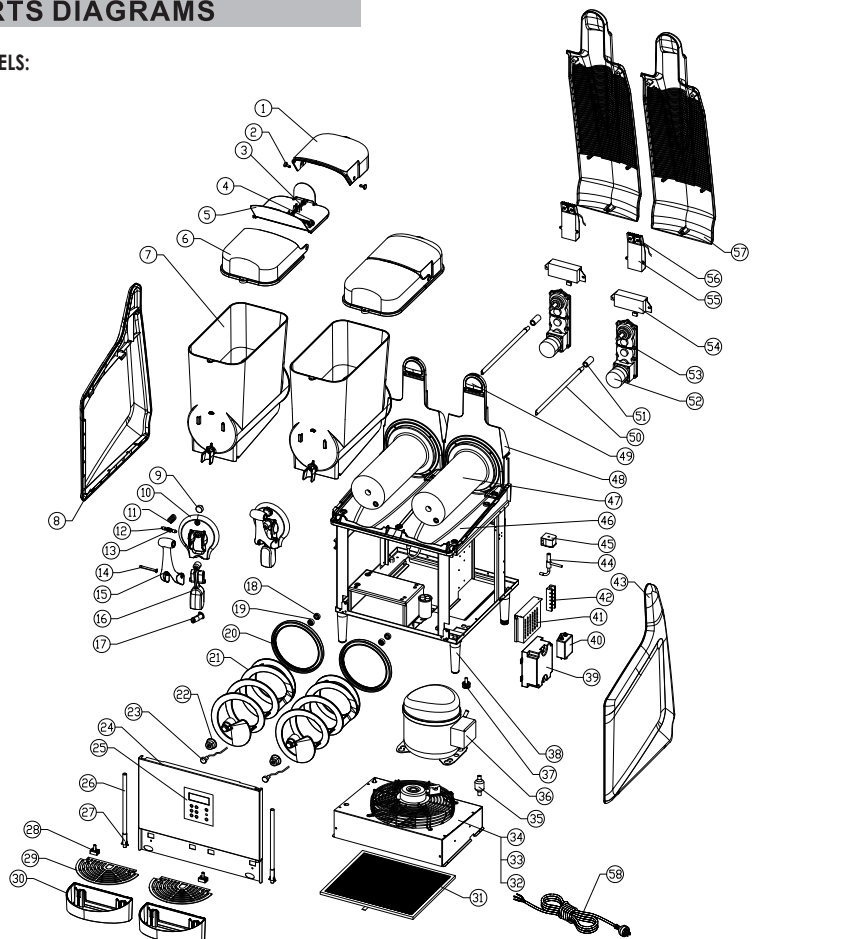

- |                            |                          |                                  |                                  |
|----------------------------|--------------------------|----------------------------------|----------------------------------|
| 1. Back lid                | 16. Outlet               | 31. Dust screen                  | 46. Base of evaporator           |
| 2. Retaining plug          | 17. Seal of outlet       | 32. Condenser                    | 47. Evaporator                   |
| 3. Rack for top cover      | 18. Washer of axis       | 33. Condenser fan motor          | 48. Seat of evaporator(back)     |
| 4. Top cover axis          | 19. Seal of axis         | 34. Cover of condenser fan motor | 49. LED light Holder             |
| 5. Inner lid               | 20. Seal of evaporator   | 35. Filter                       | 50. Axis                         |
| 6. Front lid               | 21. Auger                | 36. Compressor                   | 51. Connector of axis            |
| 7. Bowl                    | 22. Seal of auger        | 37. Adjustable screw             | 52. Motor                        |
| 8. Left side panel         | 23. Temp sensor          | 38. Feet                         | 53. Gear                         |
| 9. Screw of tap            | 24. Front panel          | 39. Controller                   | 54. Driver of Brushless DC motor |
| 10. Panel for handle       | 25. Controller sticker   | 40. EMI filter                   | 55. Coolingfin                   |
| 11. Spring for handle      | 26. Drain Pipe           | 41. Power supply                 | 56. RGB light                    |
| 12. Nozzle mounting column | 27. Outlet of drain pipe | 42. Socket                       | 57. Back panel                   |
| 13. Spring for tap         | 28. Float indicator      | 43. Right side panel             | 58. Power cord                   |
| 14. Handle bolt            | 29. Lid of water tray    | 44. Solenoid valve body          |                                  |
| 15. T shape handle         | 30. Driptray             | 45. Solenoid valve coil          |                                  |

# 11. PARTS DIAGRAMS

110V MODELS:

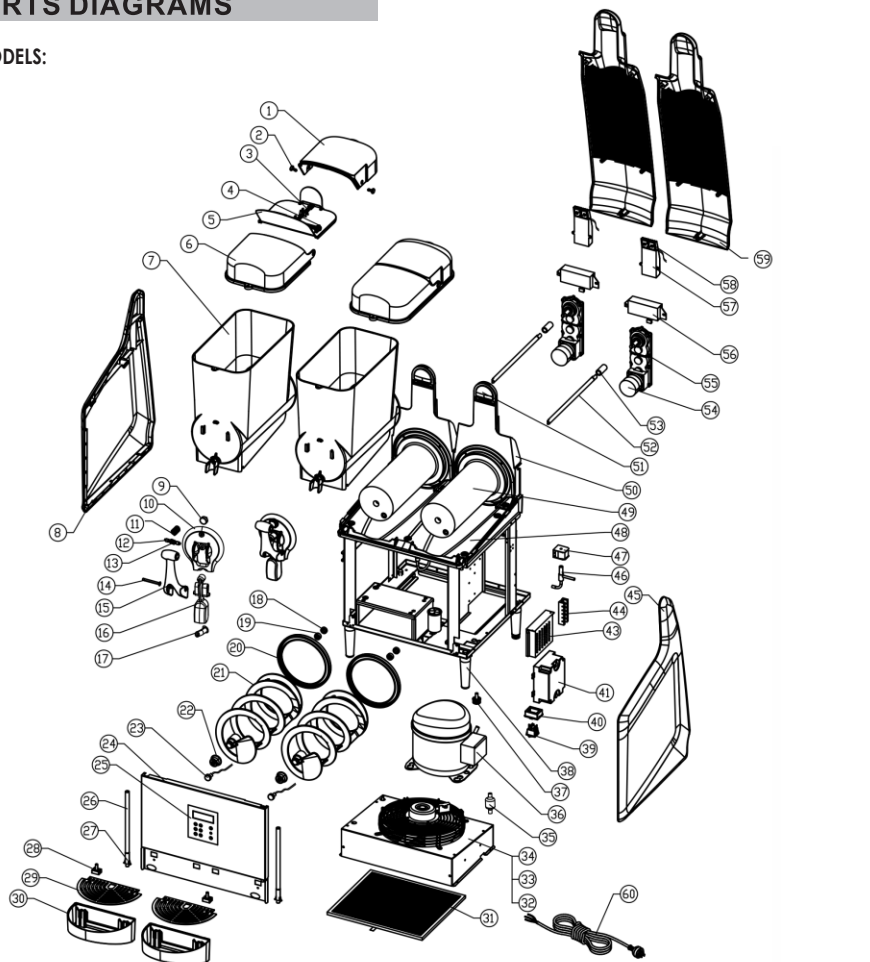

- |                            |                          |                      |                                  |
|----------------------------|--------------------------|----------------------|----------------------------------|
| 1. Back lid                | 16. Outlet               | 31. Dust screen      | 46. Solenoid valve body          |
| 2. Retaining plug          | 17. Seal of outlet       | 32. Condenser        | 47. Solenoid valve coil          |
| 3. Rack for top cover      | 18. Washer of axis       | 33. Condenser fan    | 48. Base of evaporator           |
| 4. Top cover axis          | 19. Seal of axis         | 34. Condenser motor  | 49. Evaporator                   |
| 5. Inner lid               | 20. Seal of evaporator   | 35. Filter           | 50. Seat of evaporator(back)     |
| 6. Front lid               | 21. Auger                | 36. Compressor       | 51. LED light Holder             |
| 7. Bowl                    | 22. Seal of auger        | 37. Adjustable screw | 52. Axis                         |
| 8. Left side panel         | 23. Temp sensor          | 38. Feet             | 53. Connector of axis            |
| 9. Screw of tap            | 24. Front pane           | 39. Power switch     | 54. Motor                        |
| 10. Panel for handle       | 25. Controller sticker   | 40. Panel of switch  | 55. Gear                         |
| 11. Spring for handle      | 26. Drain Pipe           | 41. Controller       | 56. Driver of Brushless DC motor |
| 12. Nozzle mounting column | 27. Outlet of drain pipe | 43. Power supply     | 57. Coolingfin                   |
| 13. Spring for tap         | 28. Floatindicator       | 44. Socket           | 58. RGB light                    |
| 14. Handle bolt            | 29. Lid of water tray    | 45. Right side panel | 59. Back panel                   |
| 15. T shape handle         | 30. Driptray             |                      | 60. Power cord                   |





